

# SAGAEN OM DEN GANGEN ASKERLIAS 2000 BEBOERE LØSTE ET STORT PROBLEM

SAMMEN MED  
ASKER  
KOMMUNE



# PROLOG

Lykken var stor på Borgen når politikerne og kommuneadministrasjonen ville bygge ny barnehage på Bondivann stasjon



RETTE VED  
SIDEN AV  
ER DET EN  
GAMMEL GANGSTI  
TIL  
TOGSTASJONEN



MEN

ASKER  
KOMMUNE

VI HAR IKKE  
PENGER

UTSETTES

UTSETTES

I MANGE ÅR



SIDEN  
BARNEHAGEN  
BLE UTSATT  
BLE  
FORTAUET  
UTSATT OGSÅ

BOFF

...litt opp i  
veien skjer  
det også  
andre ting

Dette protesterte  
Askerlia og  
Borgen Vel  
mot med sine  
3300 beboere

EN GANGBRO VED  
EN EXTRA-BUTIKK  
SKAL RIVES...



...FOR KOMMUNEN  
HAR IKKE PENGER.



MEN DEN BRUKES  
AV SKOLEBARN.



VED RØNNINGEN  
SKOLE



**..og ikke  
nok med  
det**

**ASKER KOMMUNE  
HANDLINGSPROGRAM  
2024**

**SKOLER PÅ-  
VURDERINGS-  
-LISTE**

1	_____
2	_____
3	_____
4	_____
5	_____
6	_____

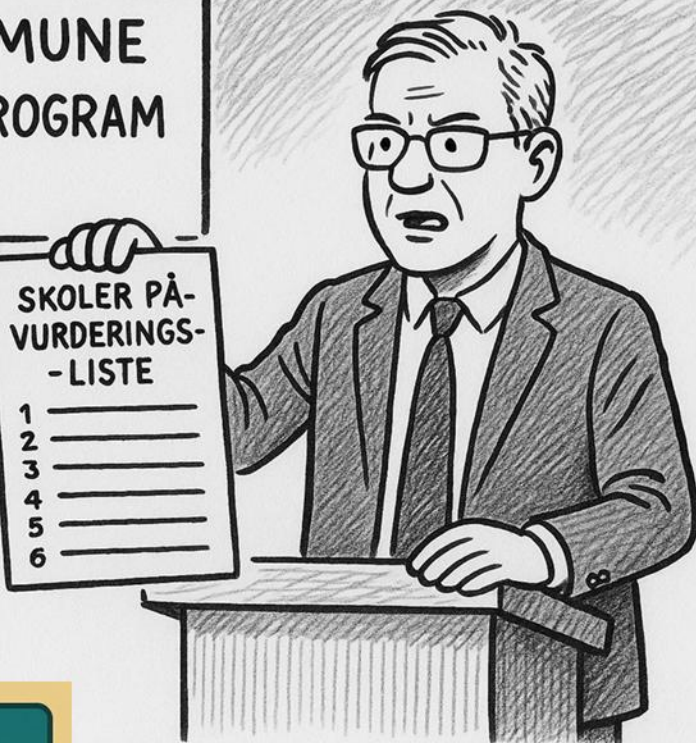

**RØNNINGEN  
BARNESKOLE**



**I PRESENTASJONEN  
AV HANDLINGS-  
PROGRAMMET  
2024  
STOD RØNNINGEN  
PÅ EN LISTA AV  
8 NEDLEGGINGSTRUETE  
SKOLER**

**RØNNINGEN  
SLAPP UNNA,**

**DENNE GANGEN,  
MEN BARNETALLENE  
MÅ OPP.**

**PHU.**



**FLERE BARN,  
ENTEN GJENNOM  
ORGANISK VEKST  
ELLER INNFLYTTERE**



**SAMTIDIG**

HOS NÆRMESTE  
NABO,  
ASKERLIA

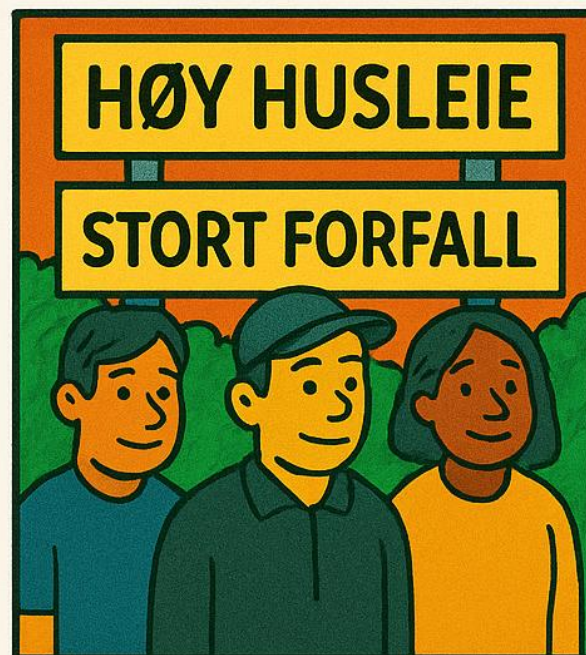
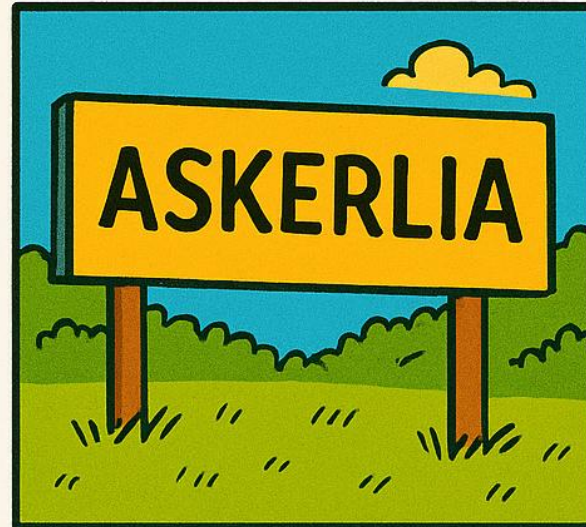
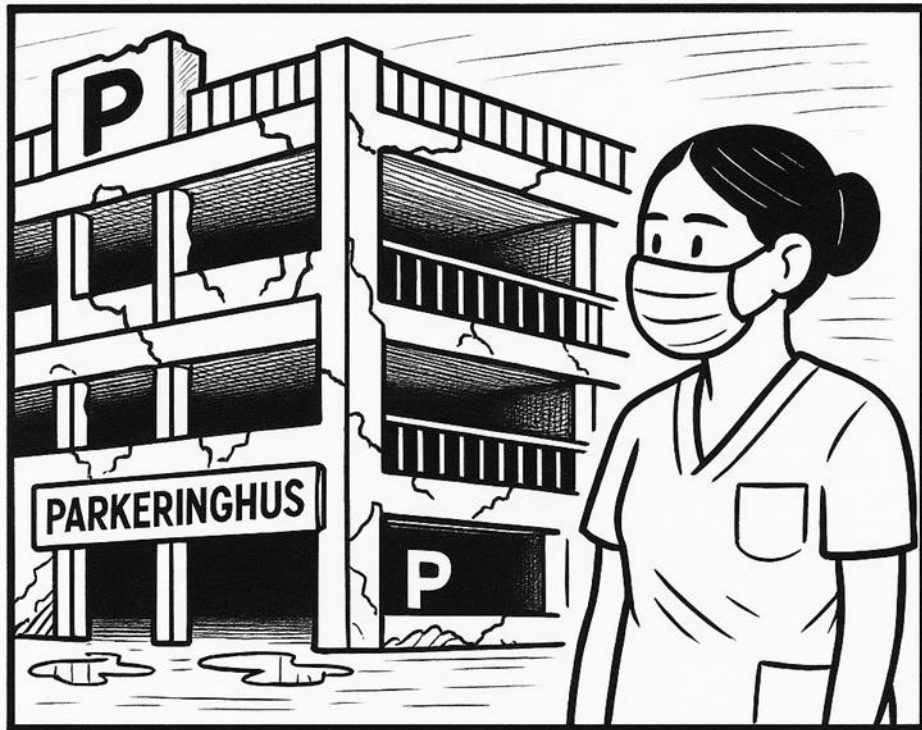

# KRISE

FOR GARASJENE  
MÅ KONDEMNERES  
OM KORT TID. DA  
MÅ ASKERLIA OMGJØRE  
GRØNTAREALER TIL  
PARKERINGSPLASSER



ASKERLIA TRENGER PENGER FOR Å BYGGE NYE GARASJER. HVORDAN SKAFFE DET?



SAMEIENE FÅR IKKE LÅNE PENGER AV BANKENE.



HUSLEIEN KAN IKKE ØKES.

DE FLESTE 654 LEILIGHETSEIERNE HAR IKKE RÅD TIL YTTERLIGERE OPPLÅNING

REHABILITERING ER IKKE MULIG DA SLITASJEN ER FOR STOR



I SISTE TAKST FRA 2023 BLE DET ESTIMERT 5 ÅRS LEVETID IGJEN PÅ GARASJENE

IKKE MULIG

ASKERLIA ER ET AV FÅ OMRÅDER HVOR VANLIG FOLK HAR RÅD TIL Å KJØPE LEILIGHET



... DERFOR ER DET VIKTIG AT ASKER KOMMUNE BIDRAR TIL AT DENNE MULIGHETEN FORTSATT FINNES

# MULIGHETEN

DET LIGGER ALLEREDE I KOMMUNEPLANEN AT MAN KAN BYGGE 100 BOLIGER OPPÅ GARASJEHUSENE,



MEN ASKERLIA SAMEIEIENE HAR FUNNET UT AT DET ER BEDRE Å DELE UTBYGGINGEN

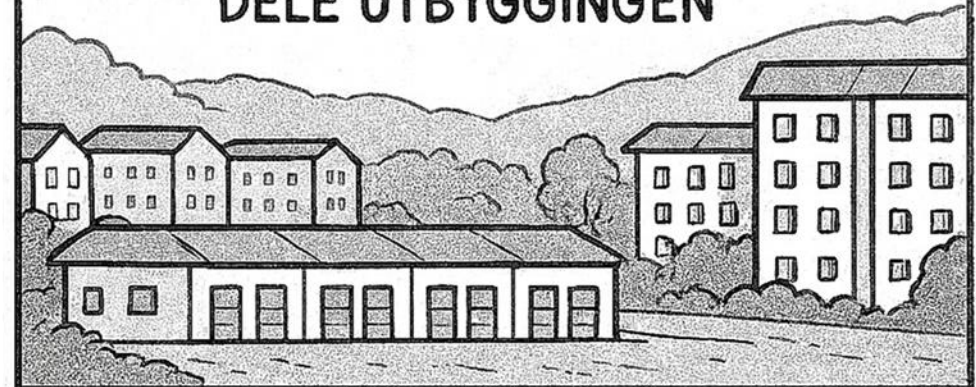

ASKERLIA SAMEIENE FÅR EN IDE FØR Å LØSE PROBLEMET



ASKERLIA HAR INNGÅTT EN AVTALE  
MED UTBYGGER OM AT DE MÅ BETALE  
MINIMUM KR 111 000 000 FOR Å FÅ  
BYGGE PÅ TOMTEN.



ASKERLIA HAR 654  
STORE LEILIGHETER  
OMRÅDET TRENGER  
FLERE MINDRE  
LEILIGHETER



Planlagt bebyggelse  
er i umiddelbar  
nærhet til  
kollektiv-  
knutepunkter





**MEN**



Det er to grunneiere,  
Asker kommune er  
en av dem



DETTE AREAL  
ER BUNDET AV  
FESTEKONTRAKT  
MED ASKERLIA

En liten del av arealet  
må få endret  
arealformål

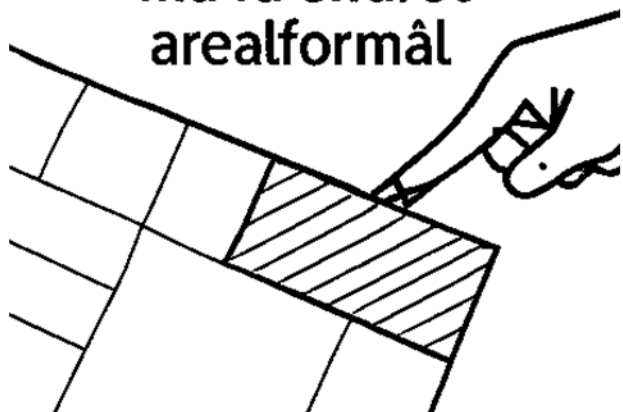

Det er sendt inn  
planforslag til  
arealplanens  
rullering



**CA. 80% AV  
AREAL ER  
REGULERT TIL  
BLOKKBEB-  
BYGGELSE**

**CA. 20%  
IKKE FESTET  
BORT, REGULERT  
I BLÅ/GRØNN  
STRUKTUR I  
BRATT TERRENG**

**ASKERLIA VIL KJØPE UT  
AREALET I BLÅ/GRØNN  
STRUKTUR OG OMLEGGES  
TRASÉEN SÅ DEN BLIR  
I HENHOLD TIL TEK 17**

**BLÅ/GRØNN STRUKTUR  
OPPRETTHOLDES  
MEN LEGGES OM**

**BLÅ/GRØNN STRUKTUR  
AREALET ER CA. 20% AV  
TOTALT UTBYGGINGSAREAL**

**ASKERLIA VIL OGSÅ  
LØSE UT RESTERENDE  
80%**

**ASKERLIA VIL  
BETALE CA.  
FEM GANGER  
MARKEDSVERDI**

**GRUNNEIERNE  
FÅR IKKE NOE  
REDUSERT  
FESTEAVGIFT**

**VI VIL HA  
MARKEDS-  
PRIS**

**INVESTORS  
OPPLEVELSE  
AV TOMTEN**



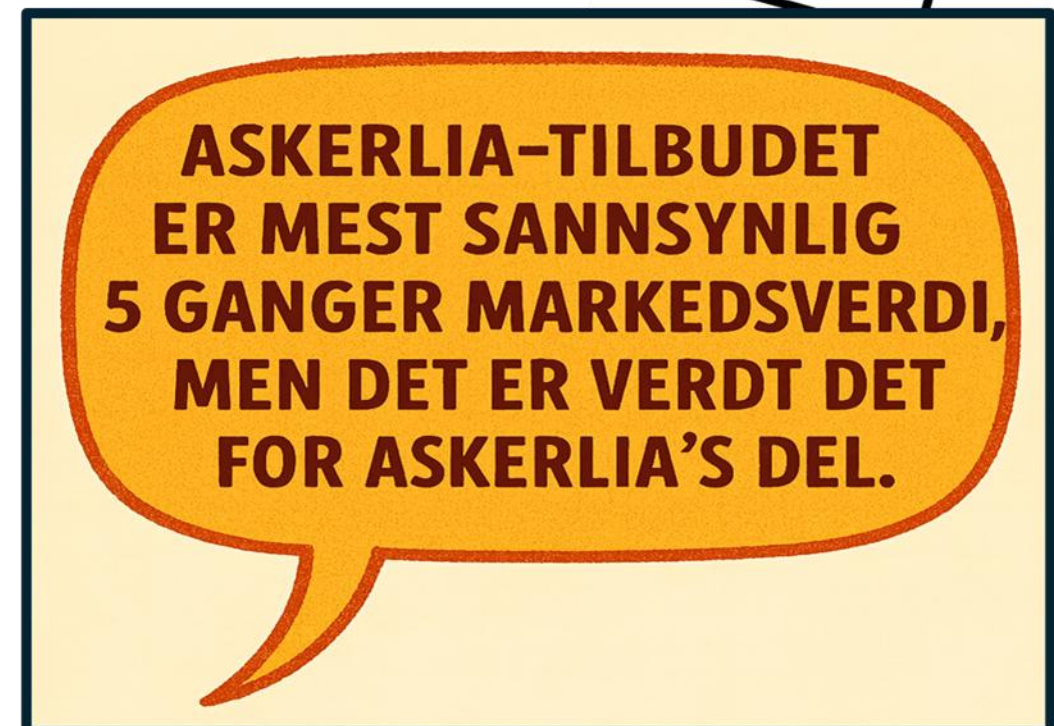

**ALT HAR GÅTT I ORDEN  
OG ASKERLIA HAR FÅTT  
INN PENGER VED  
TOMTESALGET**



MEN PENGENE GÅR IKKE TIL RIKE  
MENNESKER SOM HAR MYE FRA FØR



NYTT GARASJEHUS



NYE LEKEPLASSER

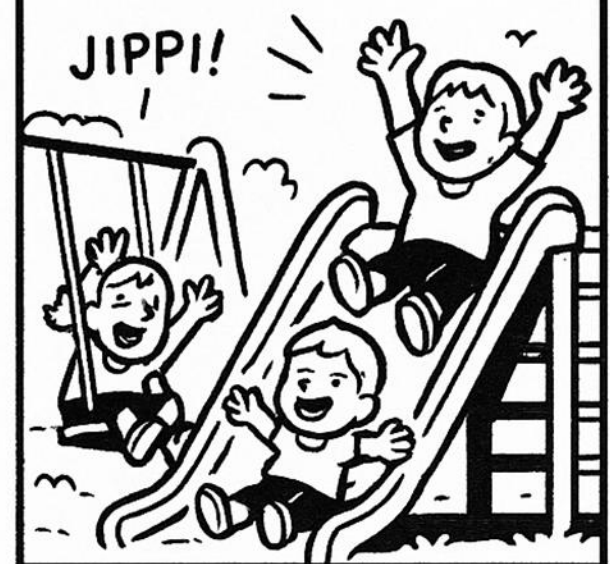

NY FOTBALLBANE



NY MØTEPlass  
FOR BEBOERNE



ALLE FORDELENE  
VI FIKK  
FORDI DETTE VAR  
ET GODT  
LAGSPILL

FOR  
GRUNNE-  
IERNE



FOR  
BORGEN/  
ASKERLIA



FOR  
KOMMUNEN



INDIREKTE  
GJENNOM  
UTBYGGINGEN



**DISSE  
FLEXI  
BOLIGENE  
VIL VI BYGGE**

**36 stk. ◦  
å 50 kvm.**

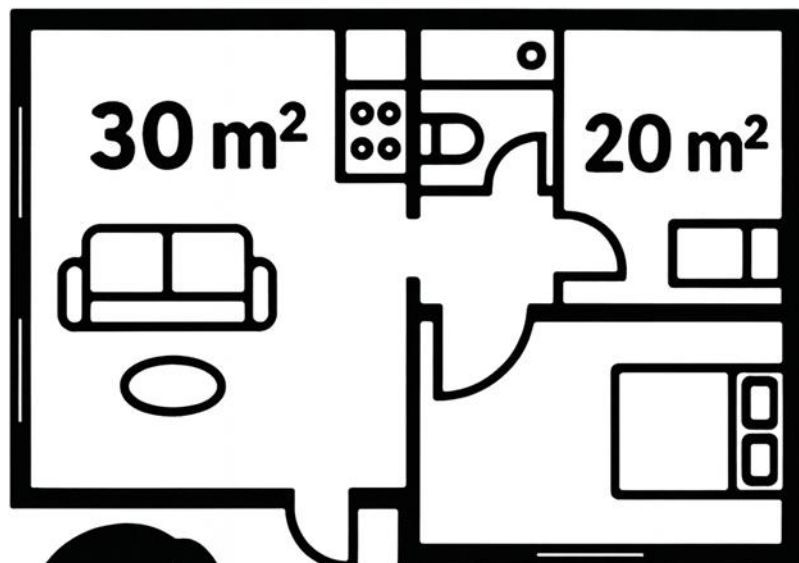

**SKATTEFRI  
INNEKT**



**NYTT  
BOLIG  
KONSEPT  
FOR AT FLERE  
KOMMER SEG INN Å  
BOLIGMARKEDET**

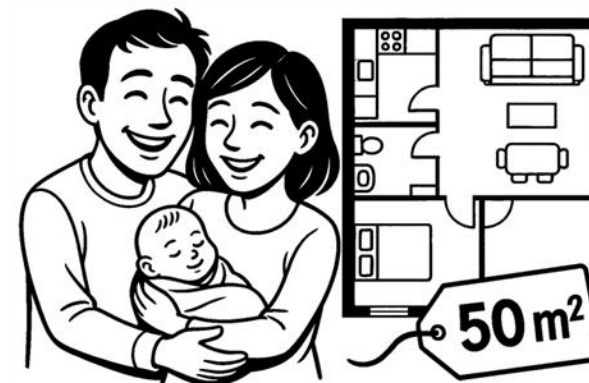

SPILLERNE

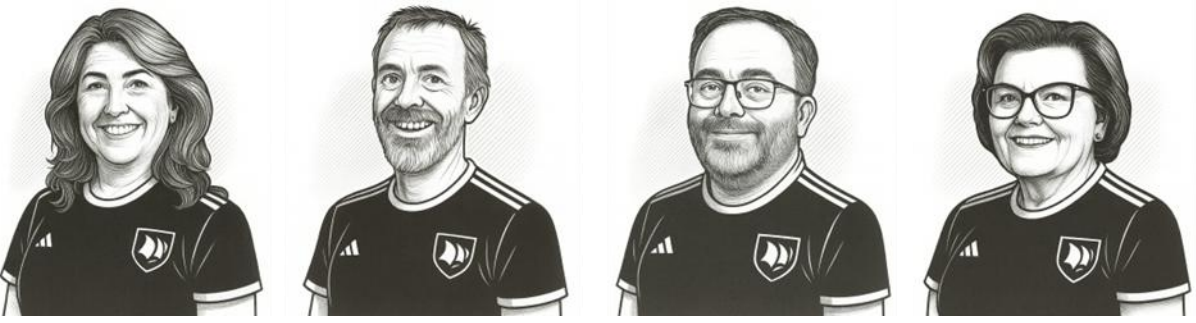

**ARENA  
ASKERLIA**

# KAMPSTART 2022



**SUPPORTERNE  
STÅR PÅ TRIBUNEN**

**DE GLEDER SEG TIL  
SPILLERNES PRESENTASJONER**

**PRODUSERT  
17 OKTOBER 2025.  
OPPLAG 20 STK.  
(IKKE INKLUDERT PRØVETRYKK).  
FOR ASKERLIA  
AV CHRISTIAN SKREDE  
BILLEDPRODUKSJON  
CHATGPT5  
GRUNNLAG FOR  
RE-TEGNEDE PORTRETTBILDER:  
ASKER KOMMUNE | /  
FOTOGRAF TORBJØRN TANDBERG**

# KAMPSLUTT 2027